

B14&B14S

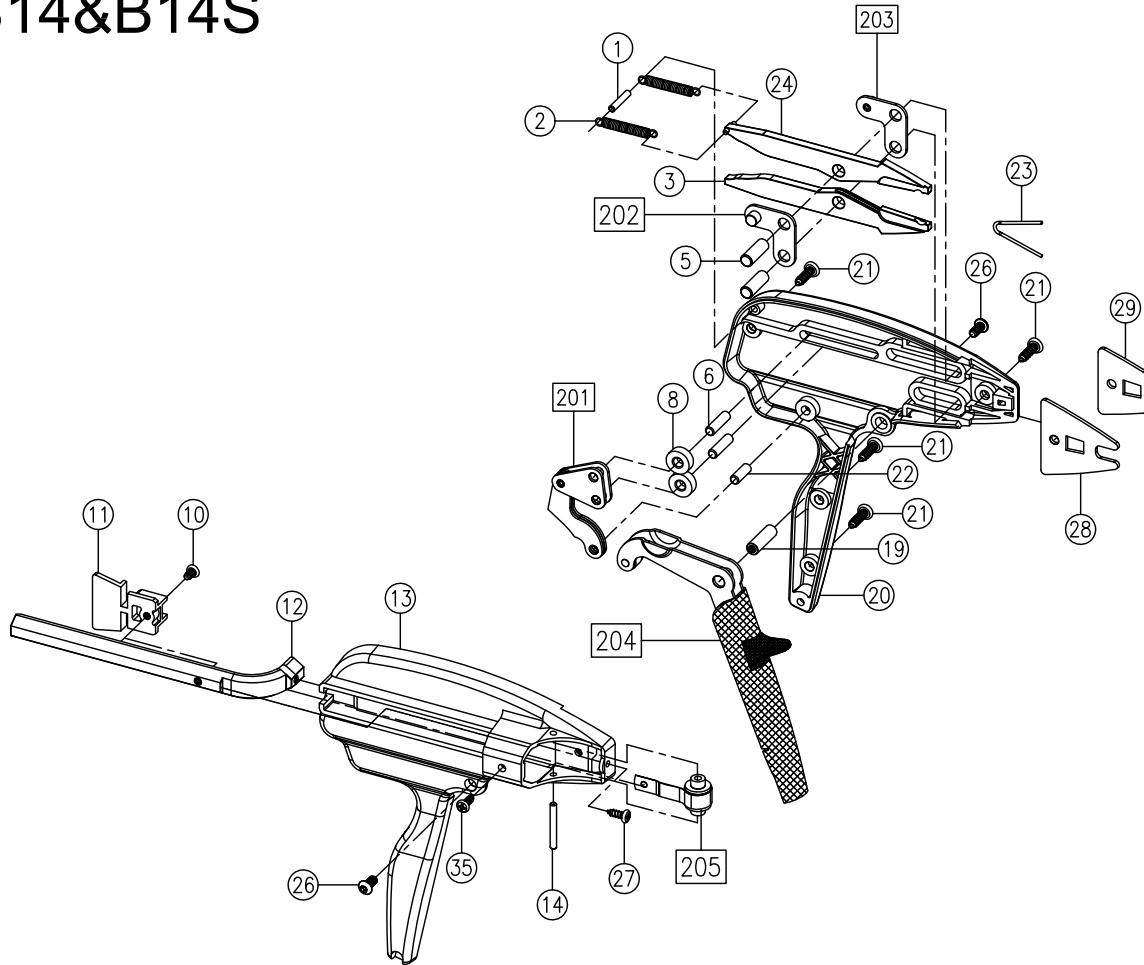

PARTSLIST

ITEM	DESCRIPTION	PART NUMBER	Q'TY	ITEM	DESCRIPTION	PART NUMBER	Q'TY
1	Pin	B14001	1	21	Screw	B14021	4
2	Spring	B14002	2	22	Pin	B14022	1
3	Lower Jaw	B14003	1	23	V Spring	B14023	1
5	Pin	B14005	2	24	Upper Jaw	B14024	1
6	Pin	B14006	2	26	Screw	B14026	2
8	Roller	B14008	2	27	Screw	B14027	1
10	Screw	B14010	1	28	Guide	B14028	1
11	Pusher	B14011	1	29	Guide (Optional)	B14S029	1
12	Magazine	B14012	1	35	Screw	B14035	1
13	Housing (Right)	B14013	1	201	Delta Lamination Assy.	B14201	1
14	Pin	B14014	1	202	Jaw Link Assy. (Right)	B14202	1
15	Pusher Spring	B14015	1	203	Jaw Link Assy. (Left)	B14203	1
16	Plastic Roller	B14016	1	204	Handle Assy.	B14204	1
19	Pin	B14019	1	205	Spring Assy.	B14205	1
20	Housing (Left)	B14020	1				

RECOMMENDED SPARE PARTS LIST

ITEM	DESCRIPTION	PART NUMBER	QTY
2	Spring	B14002	2
11	Pusher	B14011	1
12	Magazine	B14012	1
23	V Spring	B14023	1
205	Spring Assembly	B14205	1

THE WAYS OF ELIMINATING SIMPLE BREAKDOWN

◆ Jamming problems

The most common reason is insufficient pusher spring tension. This occurs when the tool is forced to function when ring quantity is not sufficient. This tool is not designed to empty its magazine during operation. Reload when the pusher makes contact with the tunnel in the housing.

If a jam occurs, pull pusher back to the locked position and pull rings out of jaw mechanism area. Point nose of tool down while holding onto rings, cycle tool slowly. User may need to shake pliers to assist the ring in falling out. This should force jammed ring out of jaw mechanism.

◆ Ring does not close completely

1. Check for foreign debris in the jaw area. This is especially true in the area between the housing and rollers.
2. The jaws may be worn from extended use, replacing the jaw(s) is recommended.
3. When the tool is used in corrosive applications, a water dispersing lubricating oil should be applied on a regular basis to the jaw pins and rollers. Unlubricated and/or corroded jaw pins may cause the tool to function poorly.

◆ Feeding problems

1. If rings do not feed smoothly down the magazine, check pusher spring for tension. If the magazine is covered with dirt from field use, clean the magazine and apply a light coating of water dispersing lubricating oil. If magazine is worn or damaged, replace it.
2. When rings feed properly on the magazine but do not feed into the jaws without spitting out of the magazine side of the tool, or if the rings sit in the jaw grooves on an angle, check jaws to insure freedom of movement.
3. If jaws do not open completely allowing the next ring to enter jaws, check the jaw open spring for wear or need of replacement.
4. Never use loose rings in the D-Ring hand Pliers B14.