

AC02 / 03 / 04 / 05

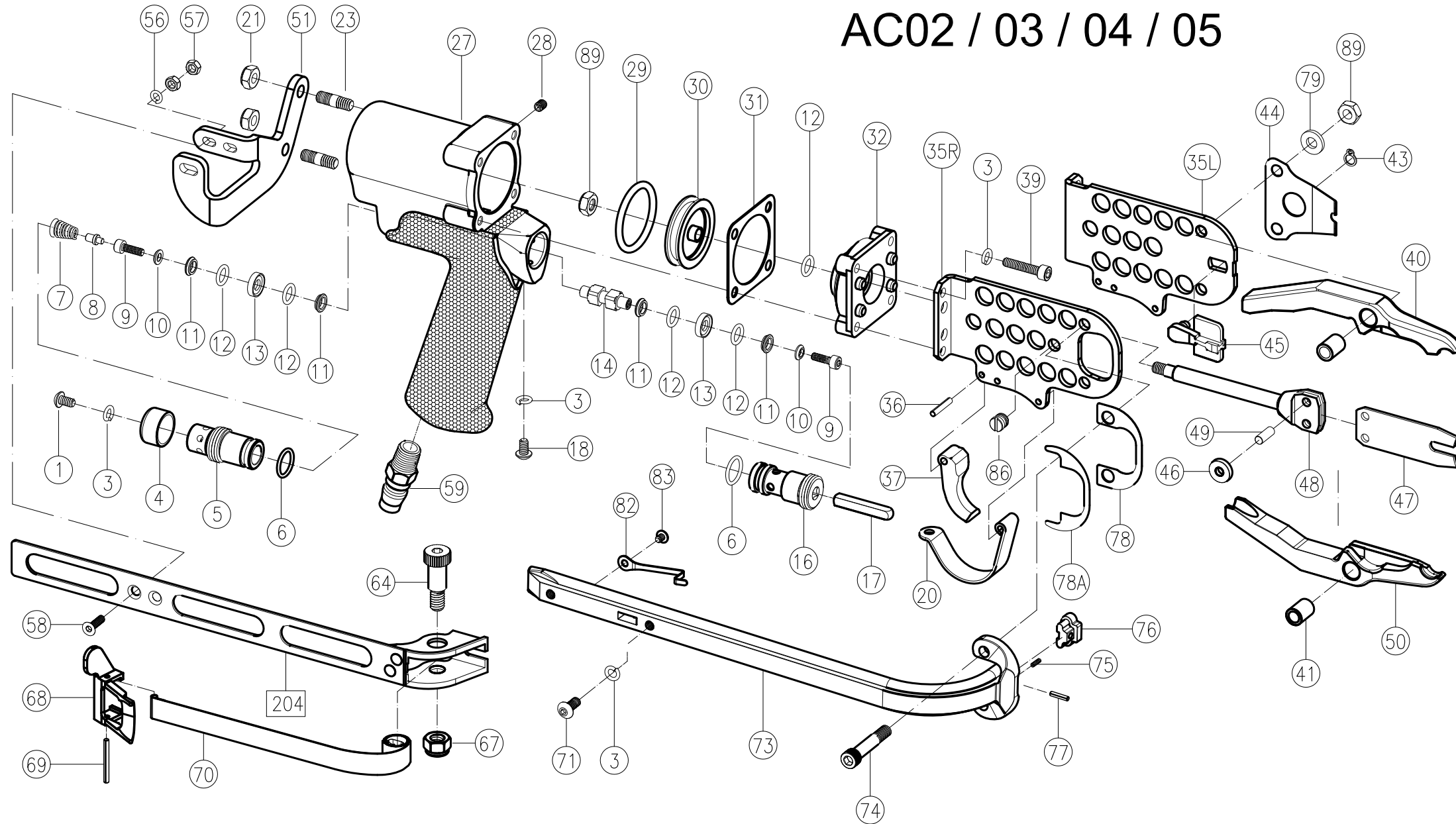

ITEM	DESCRIPTION	TOOL NO.	PART NUMBER	QTY
1	Set Screw		AC01001	1
3	Shakeproof lock Washer		AC01003	7
4	Air Deflector		AC01004	1
5	Rear Valve Seat		AC01005	1
6	O-Ring		AC01006	2
7	Throttle Spring		AC01007	1
8	Throttle Spring Locator		AC01008	1
9	Throttle Valve Screw		AC01009	2
10	Valve Screw Washer		AC01010	2
11	O-Ring Support		AC01011	4
12	O-Ring		AC01012	5
13	O-Ring Center Support		AC01013	2
14	Throttle Valve Spacer		AC01014	1
16	Front Valve Seat		AC01016	1
17	Throttle Stem		AC01017	1
18	Button Head Cap Screw		AC01018	1
20	Trigger Guard		AC01020	1
21	Flexloc Nut		AC01021	2
23	Stud		AC01023	2
27	Housing		AC01027	1
28	Set Screw		AC01028	2
29	O-Ring		AC01029	1
30	Piston		AC01030	1
31	Cylinder Gasket		AC01031	1
32	Piston Stop Spacer	AC02/05	AC02032	1
		AC03/04	AC01032	
35R	Side Plate (Right)		AC0135R	1
35L	Side Plate (Left)		AC0135L	1
36	Roll Pin		AC01036	3
37	Trigger		AC01037	1
39	Socket Head Cap Screw		AC01039	4
40	Upper Jaw	AC02	AC02040	1
		AC03	AC03040	
		AC04	AC04040	
		AC05	AC05040	
41	Jaw Bushing		AC01041	2
43	Latch Pin Clip		AC01043	1
44	Latch Spring	AC02/03/04	AC01044	1
		AC05	AC05044	
45	Latch	AC02	AC01045	1
		AC03/04	AC03045	
		AC05	AC05045	
46	Roller	AC02/05	AC02046	4
		AC03/04	AC01046	
47	Feeder Blade	AC02	AC02047	1
		AC03/04	AC03047	
		AC05	AC05047	
48	Piston Rod	AC02	AC02048	1
		AC03/04/05	AC03048	
49	Roller Pin		AC01049	2
50	Lower Jaw	AC02	AC02050	1
		AC03	AC03050	
		AC04	AC04050	
		AC05	AC05050	
51	Feeder Arm		AC01051	1
56	Washer		AC01056	2
57	Nut		AC01057	4
58	Screw		AC01058	2
59	Inlet Bushing		AC01059	1
64	Socket Head Cap Screw		AC01064	1
67	Nut		AC01067	1
68	Pusher		AC02068	1
69	Extruded Rivet		AC01069	1
70	Pusher Spring		AC01070	1
71	Button Head Screw		AC01071	1
73	Magazine Body		AC02M073	1
74	Jaw Bolt		AC02074	2
75	Magazine Spring		AC02075	2
76	Magazine Shoe		AC02M076	1
77	Roll Pin		AC02077	1
78	Magazine Shim		AC01078	1
78A	Magazine Shim		AC0178A	1
79	Washer		AC01079	2
82	Clip Anti-Backup		AC02082	1
83	Screw		AC01M083	1
86	Plate Screw		AC01086	1
89	Flexloc Nut		AC01089	3
200	Housing Assembly		AC01200	1
201	Assembly	AC02	AC02201	1
		AC03/04	AC03201	
		AC05	AC05201	
202	Assembly	AC02	AC02202	1
		AC03/04	AC03202	
		AC05	AC05202	
203	Frame Assembly		AC01203	1
204	Feeder Guide Rail		AC02204	1
205	Pusher Assembly		AC02205	1
206	Magazine Assembly		AC02M206	1

NO.202 Assembly
47,48,49

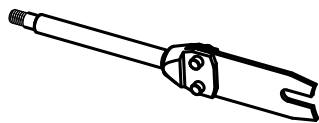

NO.201 Assembly
12,29,30,31,32,47,48,49,89

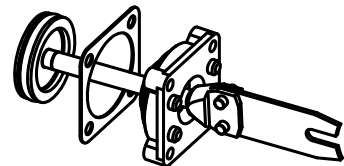

NO.203 Frame Assembly
20,35R,35L,36,37,86

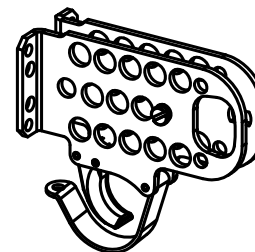

NO.200 Housing Assembly
23,27,28

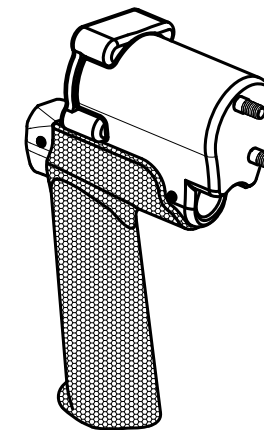

NO.205 Pusher Assembly
68,69

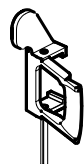

NO.206 Magazine Assembly
73,75,76,77,82,83

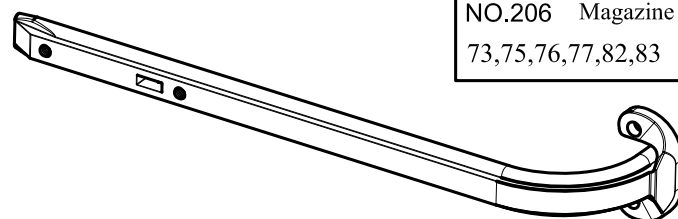



ANN-CHAIN ENTERPRISE CO., LTD.
NO.65-5, LANE 540, YOAN-FONG RD.,
CHANG HUA CITY, TAIWAN, R.O.C.
TEL: 886-4-7521297 FAX: 886-4-7521293

PNEUMATIC CLIP RING TOOL AC02, AC03, AC04, AC05



OPERATING INSTRUCTIONS & PARTS LIST

For best operating results and long life, maintain the tool in good working order, do not drop the tool, keep the mechanism free from dirt and other foreign matter and do not operate the tool at air pressures above 100 PSI (7.03 kg/cm²). Although your clip ring tool is of high quality and made to exacting standards, failure to follow proper operational precautions may result in damage to your tool and shorten its useful life.

OPERATION

The air powered clip ring tool should be held firmly in the hand and in most operations the tool is used 90 degrees to the work performed. It should be kept in mind that in using the air powered clip ring tool, this is like any other tool and should be properly maintained. One area of maintenance to be conscious of is when pushing the tool into foam, it should be cleaned occasionally. Also, when "grabbing" a group of wire, the tool is frequently used as a pusher puller and/or a variety of other things. The most important point to remember is to take a long, hard look at your work and choose the best way in which to do it. Obviously, the less the tool is abused, the better. The tool should be handled firmly in your hand and don't stretch too far when you use it in the direction of your application. Please also note that the tool should make a complete closure of the fastener. If for any reason you are not getting complete closure, check to make sure that the application is correct and that the tool is cycling completely. Obviously, moisture, dirt or any other foreign matter that is inside the tool will reduce its Operational efficiency. Please take care in handling, operation and maintenance of your tool for a long and useful work life.

AIR PRESSURE

Air pressure should be maintained at 85-96 PSI (5.98-6.68 kg/cm²) using 1/4" (6.35mm) ID air hose. Higher pressures will not increase the operating speed of the tool and may cause damage to it.

AIR FILTER AND REGULATOR

The air line should have an attached air line filter and regulator sufficient to provide a constant and even flow of clean, dry air. The filter should be installed as close as possible to the tool. Dirt or moisture in the air line will adversely affect the smooth operation of the tool and decrease its serviceable life.

LUBRICATION

To insure long, trouble-free service, we recommend Air Line Lubricators and Filter Units for proper lubrication and clean, dry air. A good grade of oil that emulsifies in water is recommended for air tools.

MANUAL OILING

Although the jaws and other moving parts of the tool do need to be oiled, periodic oiling in small amounts may increase the serviceable life of the tool that receives heavy use.

C-RINGS

These rings are available from ANN-CHAIN and will be shipped promptly from stock. PLEASE SEE C-RING STYLES CHART for further details regarding materials, points and size of C-RING.

REPAIR AND SERVICE PARTS

If any tool is not operating properly, remove it from service at once and have it checked for proper operation. ANN-CHAIN will ship replacement parts for repairs. Parts price lists are available upon request. Use only parts that are specifically fabricated for the AC model tool which you own.

TO DISASSEMBLE

Jaws, Magazine, Feeder Guide Rail

Remove Flexlock Nuts(21) and Jaw Bolts (#74). Take out Jaws(#40 and #50). Remove Magazine Assembly(#73) and Feeder Guide Rail (#204).

Feeder Blade, Rollers and Piston Rod

Remove Cap Screws (#18 & #39 x 4 pcs) and Frame Assy. (203) from Cylinder Housing. After taking off Piston(#30) and Piston Stop Spacer (#32). Piston Rod Assembly with Feeder Blade (#47) and Rollers (#46 x 4 pcs) can be taken out the front end of the Frame.

THROTTLE

Loosen Set Screws (#28) and remove Adjustable Valve Seats (#5 & #16). Using two Allen wrenches, unscrew Throttle Valve Screw (#9) to remove Valve units. One Valve will stay on Spacer (#14) and can be disassembled after removal from Housing.

TO ASSEMBLE

Assemble one Valve on Spacer (#14). Holding Allen wrench, bring second Valve mounted on Screw (#9) in from other side and complete Valve Assembly (should then have free motion of about 1/16").

THROTTLE VALVE ADJUSTMENT

With Throttle Spring Locator (#7 & #8) in place, partially screw in Adjustable Valve Seat (#5). With air partly turned on and holding front Valve closed with a 3/8" dia. turn Valve Seat in until air stops leaking through Valve. Using Throttle Stem (#17) to turn, install Front Valve Seat (#16), turning until air stops exhausting through Handle. After finer adjustment, lock Valve Seats in place with Set Screws (#28) in Housing casing.

TO LOCATE AND CORRECT AIR LEAKS

If an Adjustable Valve Seat is turned too far, the opposite Valve will be raised from its Bushing Seat, causing air leakage. To correct back off Adjustable Valve Seat until leak stops. If leaks do not stop, check Piston (#30) and Piston O-Ring (#29).

FEEDER BLADE, ROLLERS, PISTON ROD

Onto Piston Rod (#48) mount Feeder blade (#47), Roller Pins(#49 x 2pcs) and Rollers (#46 x 4 pcs). Put in Frame. Mount Piston Stop Spacer (#32), Piston (#30) and Flexloc Stop Nut (#21). Insert Throttle Stem (#17) and then assemble Frame to Housing.

FEEDER GUIDE RAIL

With Feeder Arm (#51) in place, assemble Feeder Guide Rail(#204). Pusher spring (#70), slide into Bracket and insert lower Cap Screw (#64) tight. Continue turning to desired Pusher Spring tension and lock with Nut (#67).

MAGAZINE

Assembly Latch(#45) and Latch Pin Clip (#43). Insert Jaw Bushings (#41 x 2 pcs) into Jaws (#40 & #50), side jaws into place and complete assembly.

ADJUSTMENT OF MAGAZINE

Before tightening Cap Screws (#74), insert enough Shims (#78) between Magazine(#73) and Side Plate(#35R) to produce a clearance between Magazine Shoe(#76) and Feeder Blade (47). Magazine must be held tight against Side Plate while checking this clearance; then, after tightening the Cap Screws (#74 x 2 pcs), clearance should be rechecked.

**DO NOT POINT THE TOOL AT ANY PERSON.
KEEP HANDS AND CLOTHING AWAY FROM
THE FRONT OF JAWS OF THE TOOL AND
AWAY FROM ALL MOVING PARTS. INJURY
MAY RESULT. FAILURE TO FOLLOW THESE
PRECAUTIONS MAY RESULT IN SERIOUS
INJURY.**